

# NORTHEAST Combat Pistol League

**Scenario Name: Rifle Match #16**

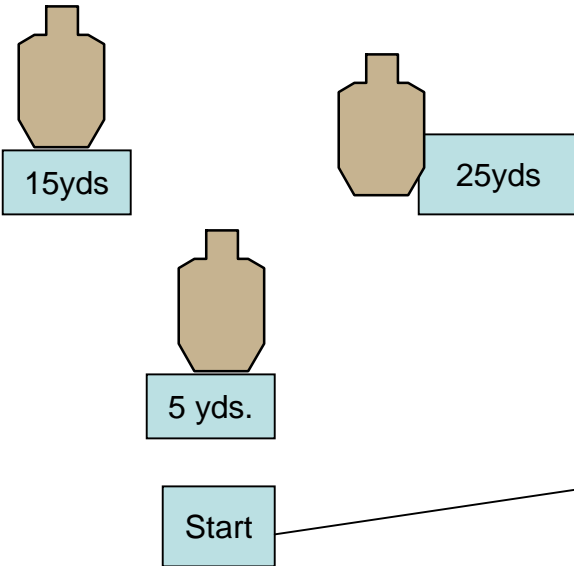
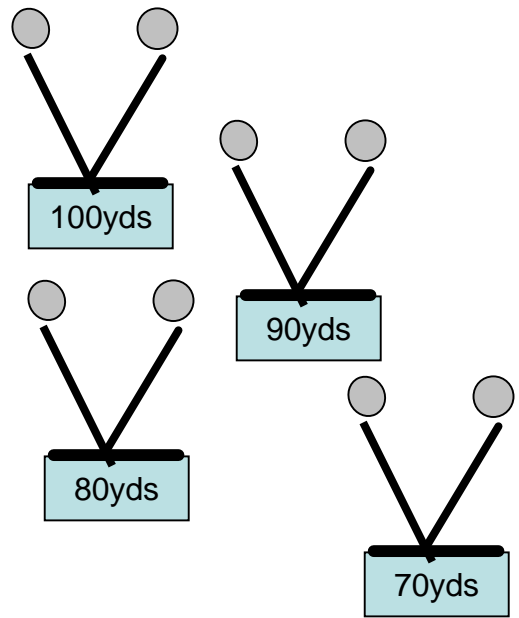
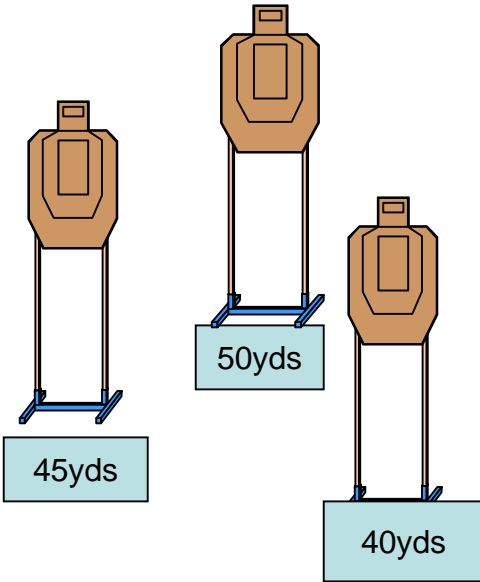

**Shooter stands in start position with rifle loaded at low ready position. At signal, engage paper with 3 rounds min. in any order. Move to barrel at #2 and engage all steel lollipops with 1 round from prone. 1 Mag change is mandatory.**

*Rounds Minimum 26 Place targets safely within berm limits Vickers Count*

**NO ARMOR PIERCING AMMO ALLOWED**

**Bipods are OK**

**\*\*\*Note: COF may be adjusted at Match Directors discretion\*\*\***